

1 PRODUCT OVERVIEW

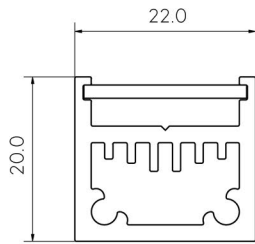

SONNY SIDE UP 22

2 JOIN EXTRUSIONS, ASSEMBLE ROD SUSPENSIONS

1. IF USING MULTIPLE LENGTHS OF EXTRUSION, SLIDE EXTRUSIONS TOGETHER ON TO JOINER OR BEND PLATE. DO NOT TIGHTEN GRUB SCREWS YET.
2. **IMPORTANT:** BEFORE MOUNTING LED STRIP, CLEAN EXTRUSION USING AN ALCOHOL BASED CLEANER.
3. REMOVE BACKING FROM LED STRIP TO EXPOSE STICKY SURFACE. LAY LED STRIP INTO EXTRUSION, UNDER THE JOINER BRACKET.
4. SLIDE DIFFUSERS INTO EXTRUSION.
5. SCREW 'COLLAR' ON TO 'ROD SUSPENSION'.
6. INSERT 'BASE' THROUGH 'ROD SUSPENSION BRACKET', AND SCREW 'COLLAR' AND 'BASE' TOGETHER LOOSELY. DO NOT TIGHTEN YET.
6. SLIDE 'ROD SUSPENSION BRACKETS' INTO EXTRUSION (SEE FIG 1) AND TIGHTEN 'ROD SUSPENSION'. THE 'BASE' WILL STOP ROD SUSPENSION FROM SPINNING AND ALLOW IT TO TIGHTEN. (SEE FIG. 2).
7. LOCK EXTRUSIONS IN PLACE BY TIGHTENING GRUB SCREWS IN JOINER BRACKET. BE CAREFUL NOT TO TIGHTEN ON TO LED STRIP OR CABLE.

FIG. 1 - ENSURE SUSPENSION BRACKET IS SECURE IN EXTRUSION

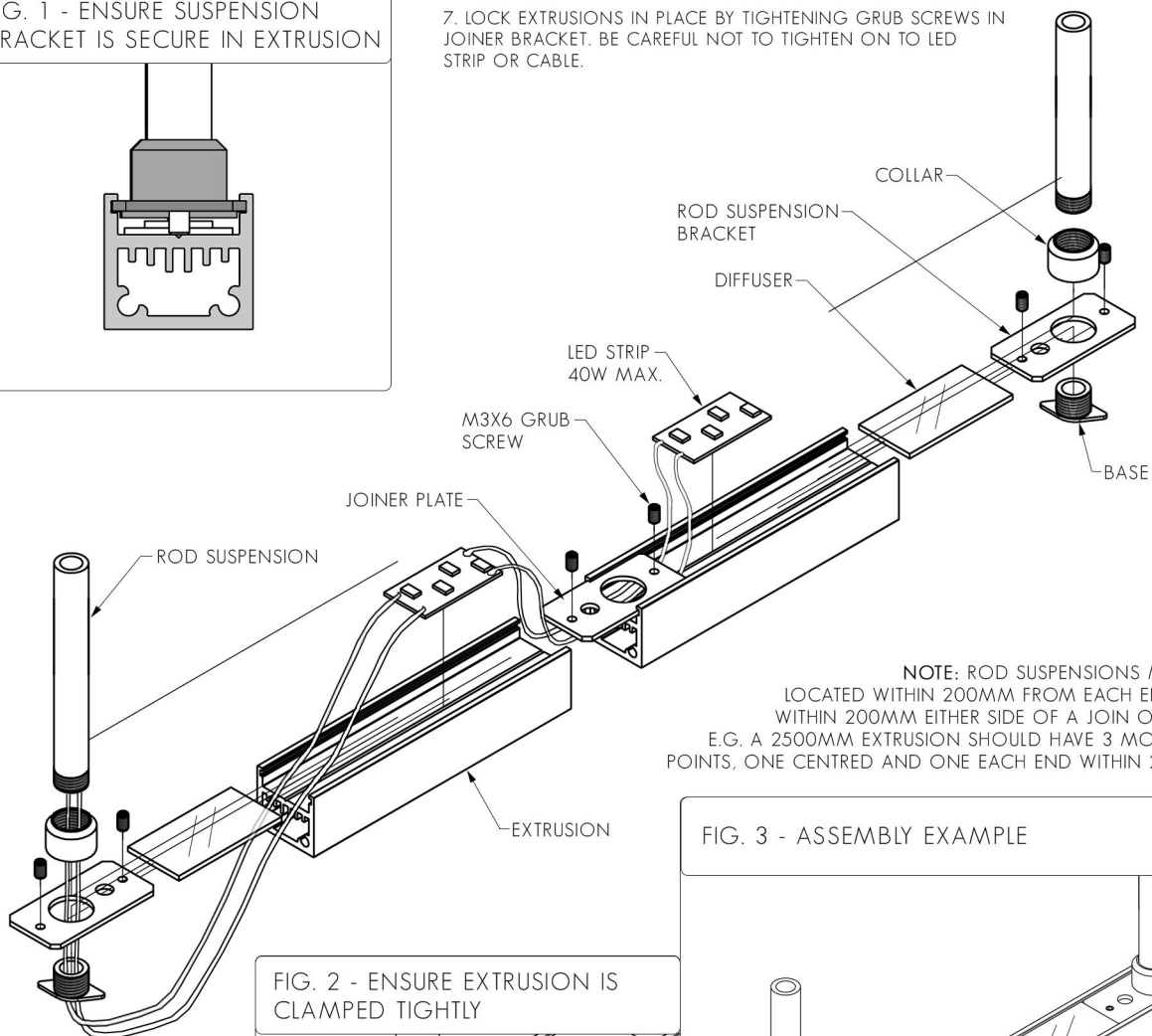
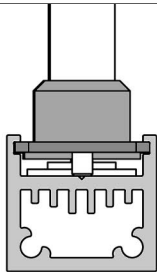

FIG. 2 - ENSURE EXTRUSION IS CLAMPED TIGHTLY

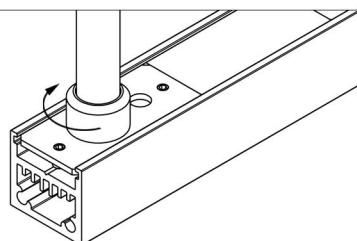
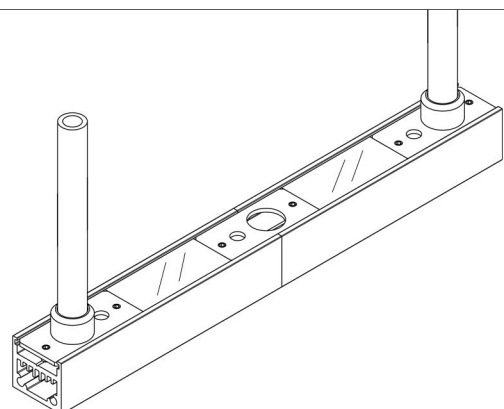

FIG. 3 - ASSEMBLY EXAMPLE



3 ATTACH CEILING BRACKETS, HANG SUSPENSION RODS, MAKE ELECTRICAL CONNECTION, INSTALL END CAPS

1. LIFT LIGHT ASSEMBLY UP TO CEILING AND MARK LOCATIONS OF RODS ON CEILING. USE MARKINGS TO CUT 47-48MMØ HOLES FOR CABLE BASES. (RECESSED VERSION ONLY - SEE FIG. 7 FOR SURFACE MOUNTED VERSION).

2. SCREW CEILING BRACKETS INTO FRAMING BEHIND PLASTERBOARD.

3. MAKE ELECTRICAL CONNECTION: CONNECT LED STRIP TAILS TO LED DRIVER USING CRIMP CONNECTORS, THEN SEAL WITH HEAT SHRINK.

4. LIFT LIGHT ASSEMBLY AND INSERT SUSPENSION RODS INTO CEILING BRACKETS, STARTING WITH THE POWER SUPPLY END. LOCK IN TO PLACE BY TIGHTENING GRUB SCREW ON ONE SIDE AND HEX HEAD SCREW ON OTHER SIDE, ENSURING HEX HEAD SCREW FITS THROUGH 4MMØ HOLE IN SUSPENSION ROD (SEE FIG. 5)

5. PUSH CABLE BASE INTO HOLE IN CEILING (SEE FIG. 6 OR FIG. 7 FOR SURFACE MOUNTED CABLE BASE).

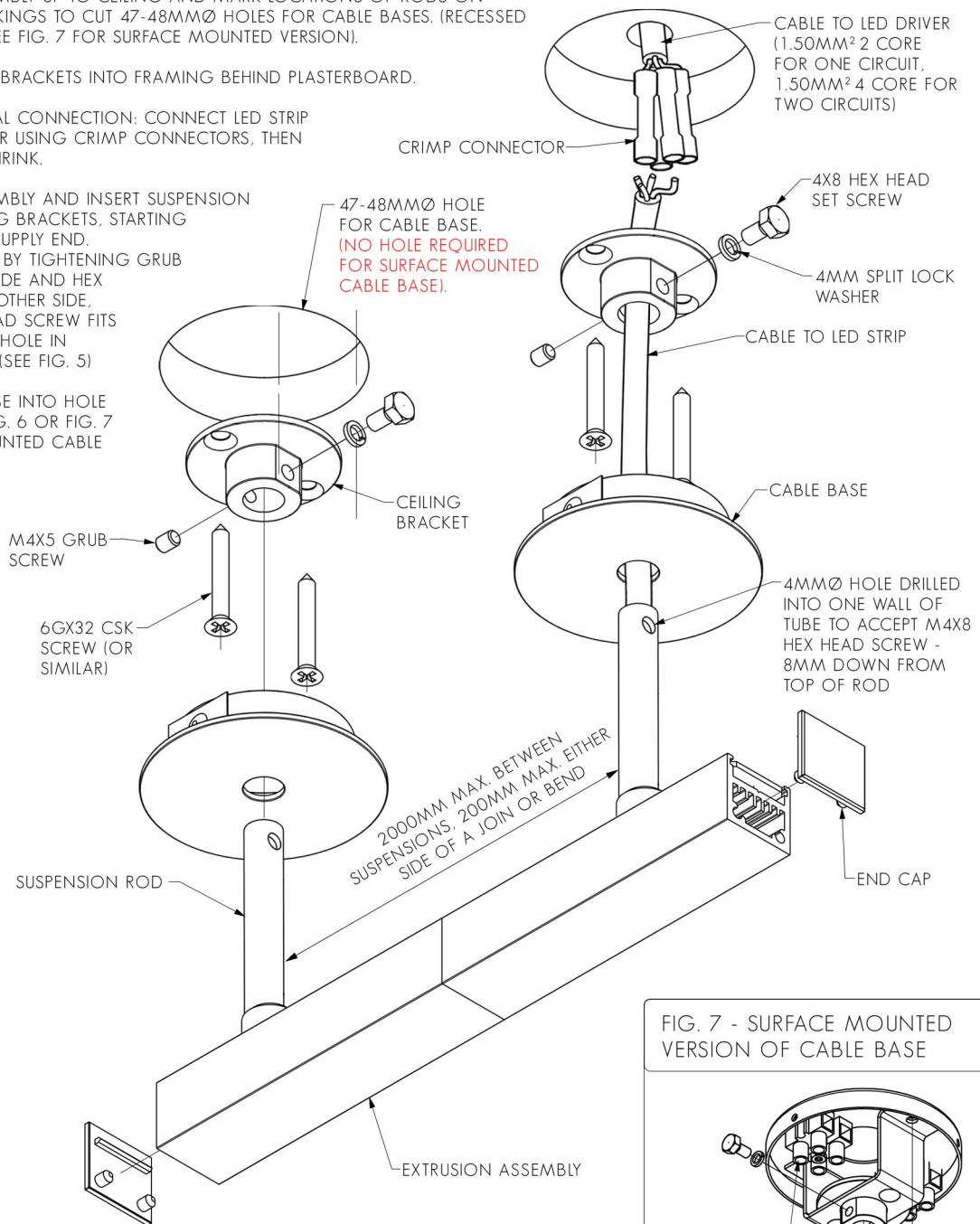

FIG. 7 - SURFACE MOUNTED VERSION OF CABLE BASE

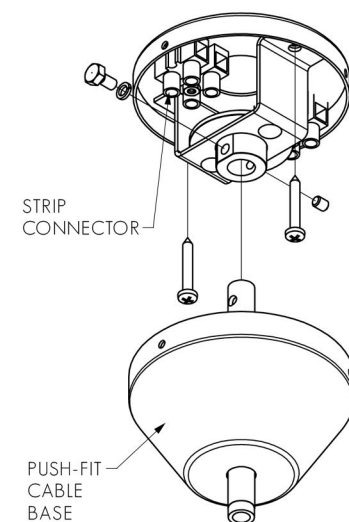

FIG. 5 - ENSURE SUSPENSION RODS ARE TIGHTLY SECURED

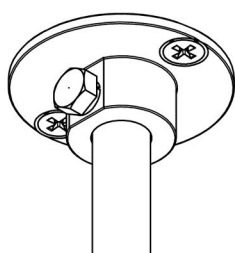

FIG. 6 - INSERT CABLE BASE IN TO CEILING

ANGLE CABLE UP IN TO HOLE, USING THUMBS TO COMPRESS SPRING CLIP ON ONE SIDE.

